

Michigan Fiero Club Recall Campaign 86-C-16

Bulletin Number: 86-C-16 Issued: 11-jul-1991

SUBJECT: PRODUCT SAFETY CAMPAIGN 86-C-16 REAR DISC BRAKE CONE CLUTCH PARK BRAKE ADJUSTER

MODELS AFFECTED: 1982-86 FIREBIRD AND 1984-86 FIERO FIERO MODEL VEHICLES WITH REAR DISC BRAKES AND MANUAL TRANSMISSIONS

TO: ALL PONTIAC DEALERS

The National Traffic and Motor Vehicle Safety Act, as amended, provides that each vehicle which is subject to a recall campaign of this type must be adequately repaired within a reasonable time after the owner has tendered it for repair. A failure to adequately repair within sixty (60) days after tender of a vehicle is prima facie evidence of failure to repair within a reasonable time.

If the condition is not adequately repaired within a reasonable time, the owner may be entitled to an identical or reasonably equivalent vehicle at no charge or to a refund of the purchase price less a reasonable allowance for depreciation.

To avoid having to provide these burdensome solutions, every effort must be made to promptly schedule an appointment with each owner and to repair their vehicle as soon as possible. As you will see in reading the attached copy of the letter that is being sent to owners, the owners are being instructed to contact the Pontiac Customer Assistance Center if their dealer does not remedy the condition within five (5) days of the mutually agreed upon service date. If the condition is not remedied within a reasonable time, they are instructed on how to contact the National Highway Traffic Safety Administration.

DEFECT INVOLVED

General Motors has determined that a defect which relates to motor vehicle safety exists in 1982-86 Firebird and 1984-86 Fiero model vehicles equipped with rear disc brakes and manual transmissions. These vehicles may exhibit a lack of park brake automatic adjustment leading to reduced parking brake effectiveness.

To correct this condition, all involved vehicles will have an improved design rear brake caliper actuator installed. Other repairs to restore park brake functions to proper operation may also be made in conjunction with this campaign.

VEHICLES INVOLVED

Involved are 1982-86 Firebird and 1984-86 Fiero model vehicles equipped with rear disc brakes and manual transmissions, and built within the following VIN breakpoints:

Year	Model	Plant	Beginning	Up To And Including

PONTIAC DIVISION



1982	Firebird	Van Nuys	CL512143	CL547717
1982	Firebird	Norwood	CN500009	CN525838
1983	Firebird	Van Nuys	DL204059	DL237537
1983	Firebird	Norwood	DN200005	DN237321
1984	Firebird	Van Nuys	EL200052	EL277535
1984	Firebird	Norwood	EN200001	EN250762
1985	Firebird	Van Nuys	FL200453	FL654814
1985	Firebird	Norwood	FN200007	FN241006
1986	Firebird	Van Nuys	GL200003	GL259050
1986	Firebird	Norwood	GN200006	GN251089
1984	Fiero	Pontiac	EP200003	EP336842
1985	Fiero	Pontiac	FP200004	FP276369
1986	Fiero	Pontiac	GP200005	GP283974

Involved vehicles have been identified by Vehicle Identification Number Computer Listings. Computer listings contain the complete Vehicle Identification Number, owner name and address data, and are furnished to the involved dealers with the campaign bulletin. Owner name and address data furnished will enable dealers to follow-up with owners involved in this campaign.

These listings may contain owner names and addresses obtained from State Motor Vehicle Registration Records. The use of such motor vehicle registration data for any other purpose is a violation of law in several states. Accordingly, you are urged to limit the use of this listing to the follow-up necessary to complete this campaign. Any dealer not receiving a computer listing with the campaign bulletin has no involved vehicles currently assigned.

OWNER NOTIFICATION

Owners will be notified of this campaign on their vehicles by Pontiac Division (see copy of Owner Letter included with this bulletin).

DEALER CAMPAIGN RESPONSIBILITY

Dealers are to service all vehicles subject to this campaign at no charge to owners, regardless of mileage, age of vehicle, or ownership, from this time forward.

Whenever a vehicle subject to this campaign is taken into your new or used vehicle inventory, or it is in your dealership for service in the future, you should take the steps necessary to be sure the campaign correction has been made before reselling or releasing the vehicle.

Owners of vehicles recently sold from your used vehicle inventory are to be contacted by the dealer, and arrangements made to make the required correction according to instructions contained in this bulletin.

PARTS INFORMATION

Parts required to complete this campaign are to be obtained from General Motors Service Parts Operation (GMSPO). To ensure that these parts are obtained as soon as possible, they should be ordered from GMSPO on a C.I.O. order with no special instruction code, but on advise code (2).

Description	Part Number	Quantity Per Vehicle
FIREBIRD MODEL PARTS		
Rear Brake Caliper Actuator Kit	18019028	1
Each Kit Contains: - 2 Actuator Assemblies - All Necessary Gaskets & Seals - 2 Brake Pad Dampening Springs		
Brake Pads	12300230	As Required
Levers	18010361	As Required
Parking Brake Cable - Front	10200446	As Required
Parking Brake Cable - Kit (Both Rear Cables)	10200448	As Required
P/N 10200443 - Left Rear Cable		
P/N 10200444 - Right Rear Cable		
Parking Brake Apply Handle	10046472	As Required
Brake Fluid	1052535	1 Pint
Banjo Washer	10139097	As Required
FIERO MODEL PARTS		
Rear Brake Caliper Actuator Kit	18019027	1
Each Kit Contains: - 2 Actuator Assemblies - All Necessary Gaskets & Seals - 2 Brake Pad Dampening Springs		
Brake Pads	12300238	As Required
Levers - Left Hand	18011072	As Required
Levers - Right Hand	18011073	As Required
Parking Brake Cable - Front	10200445	As Required
Parking Brake Cable - Kit (Both Rear Cables)	10200447	As Required
P/N 10200441 - Left Rear Cable		
P/N 10200442 - Right Rear Cable		
Parking Brake Apply Handle	10046473	As Required
Brake Fluid	1052535	1 Pint
Banjo Washer	10139097	As Required

DEALERS ARE TO RETURN ALL SERVICE INVENTORY OF SEAL KITS 18010453 & 18011329, ACTUATOR KITS 18016369 & 18016368, AND REAR CALIPER PART NUMBERS 18016374, 18014436 & 18014437. PLEASE IDENTIFY THESE PARTS AS A SPECIAL RETURN ON YOUR PC659 DOCUMENT.

SERVICE PROCEDURE

- A. Raise vehicle and remove both rear tire/wheel assemblies.
- B. Inspect park brake apply system for proper function, corrosion, kinks, etc. Remove nonfunctional cables.
- C. Spray equalizer and both bleeder screws with Liquid Wrench (or equivalent product). Do not remove screw at this time.
- D. Remove both rear calipers following the procedures in the appropriate Service Manual.

- E. Remove brake pads.
- F. Inspect brake pads for taper wear or excessive wear. Taper wear can be determined by taking measurements at the four points shown in the diagram below. Calculate pad taper by subtracting the thinnest point measured from the thickest point measured. The brake pads should be replaced

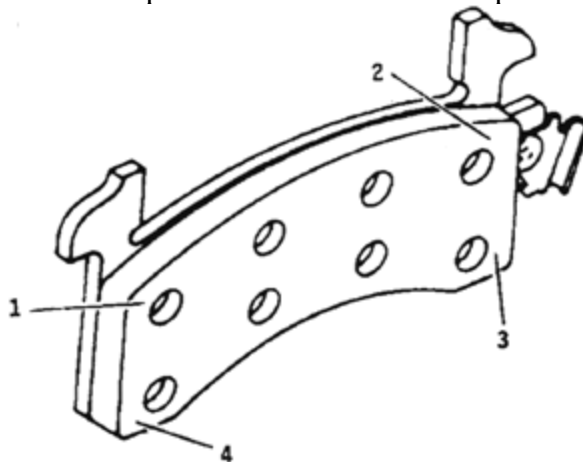

if taper is greater than .080 inches.

- G. Overhaul calipers as follows:

- Tools Required:
- * J-22269-01 Piston Installer
- * J-38898 Boot Seal Installer

1. Remove shoe damping spring from end of piston.
2. Remove park brake lever.
3. Remove lever seal and antifriction washer.
4. Remove piston by turning actuator screw with lever or wrench.
NOTICE: DO NOT REUSE OLD PISTON OR OLD BALANCE SPRING.
5. Remove actuator screw by pressing on threaded end.
6. Remove shaft seal and thrust washer from actuator screw.
7. Remove old boot while being careful not to scratch the housing bore.
8. Remove piston seal, using a wood or plastic tool that will not damage the caliper bore.
9. Remove caliper mounting bolts, bushings and sleeves.
10. Remove bleeder screw.

NOTICE: If excessive resistance is encountered, use the following procedure to prevent breakage:

(A) First put a 10mm socket over bleeder screw and tap lightly on it.

(B) If step (A) does not help, use a propane torch to heat the caliper around bleeder screw after assuring that any excess Liquid Wrench has been removed from surface. Apply heat to caliper for approximately 30 seconds to 1 minute (maximum). DO NOT USE AN ACETYLENE TORCH. Overheating of the aluminum caliper could cause the bleeder screw to strip its threads.

11. Inspect caliper bore and seal groove. If necessary, use crocus cloth to polish out any light corrosion.
12. Clean all parts with GM brake parts cleaner P/N 12345754 (or equivalent).
13. Dry parts with unlubricated compressed air.

14. Blow out all passages in housing and bleeder screw.
15. Clean internal passage in bleeder screw, reinstall bleeder screw and torque to 6-9 Nm. (80-140 lb. in.).
16. Install new piston seal. Lubricate seal and bore with brake fluid.
NOTICE: Make sure that seal is not twisted.
17. Install new lubricated boot onto new piston with inside lip of boot in piston groove and boot fold toward end of piston which contacts inboard brake pad.
18. Install thrust washer on actuator screw with copper side of washer toward the piston assembly and gray surface toward the caliper housing.
19. Install lubricated shaft seal on actuator screw.
20. Install actuator screw into piston.
21. Install new balance spring into piston recess.
22. Guide lubricated piston assembly into lubricated bore of caliper.
NOTICE: Excessive force is not required to install the piston assembly into the caliper bore. DO NOT ALLOW PISTON TO COCK IN BORE AS SEAL WILL BE DAMAGED.
23. When resistance (seal engagement) is met, rotate piston assembly back and forth to ensure it is square to seal.
24. Use #J-22269-01 to install piston through piston seal. Shake tool to align piston to the seal while gently turning the jack screw to push piston through the seal to the bottom of the caliper bore. See illustration.
25. Install lubricated antifriction washer and lever seal over end of actuator screw.
NOTICE: The sealing bead on the lever seal should be against the housing.

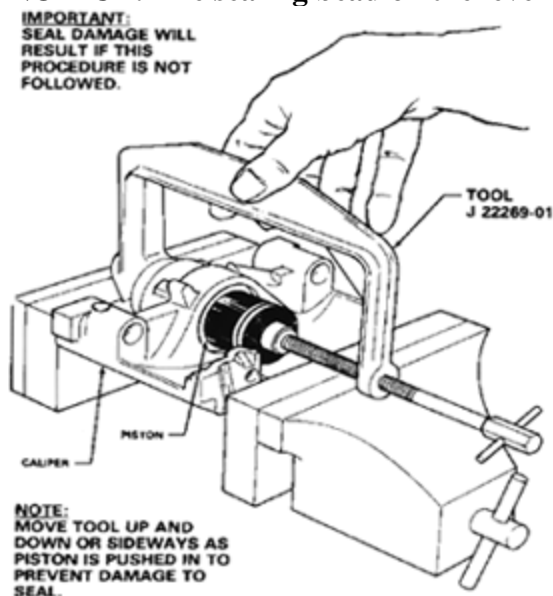

26. Install lever on actuator screw. Rotate lever away from stop slightly and hold while installing nut to 48 Nm (35 lb. ft.). Then, rotate lever back to contact stop.
27. Seat boot into caliper housing counter bore using new Kent-Moore tool #J-38898.
28. Install new brake pad dampening spring (included in kit) into groove on end of piston.
29. Clean, lubricate and reinstall sleeves, bushings and caliper mounting bolts.
30. Install brake shoes.

- H. Reinstall calipers, per the appropriate service manual.
- I. Install hydraulic fitting and bolt, using 2 new brass washers, and torque to 33 Nm (24 lb. ft.).
- J. Bleed brake system (power or manual) as required, per service manual.

- K. Apply approximately 778 N (175 lb.) force 3 times to the brake pedal to seat the linings.
- L. Clinch outboard shoe to caliper, per service manual.
- M. Readjust park brake cable, per service manual.
- N. Reinstall wheels and tire assemblies.
- O. Install Campaign Identification Label.

CAMPAIGN IDENTIFICATION LABEL

Each vehicle modified in accordance with the instructions outlined in this Product Campaign Bulletin will require a "Campaign Identification Label." Each label provides a space to include the campaign number, the five digit dealer code of the dealer performing the campaign service, and the date the vehicle was campaigned. This information may be inserted with a typewriter or ballpoint pen. Install the label only on a clean, dry surface of the radiator baffle where it is readily visible. (Additional campaign labels are available on stationery order as Form 7901-709).

CLAIM INFORMATION

A separate repair order must be used for each vehicle. A completed warranty claim is to be kept as a permanent record of completion.

DEALERS SHOULD SUBMIT WARRANTY CLAIMS FOR CREDIT IN THEIR NORMAL MANNER WHEN THEY PERFORM THE SERVICE AS FOLLOWS:

Operation	Failure Code	Labor Op	F-Car Labor Hours	P-Car Labor Hours	*Other Labor Hours	Net Item
Install New Actuator Kit	96	V6620	2.0	1.9	0.1	\$.##
Supplemental Repairs For Campaign 86-C-16	95	T1749				\$.--
ADD TIMES:						
Replace Front Park Brake Cables			0.7	0.7		
Replace Both Rear Park Brake Cables			0.2	0.3		
Replace All Park Brake Cables			0.9	0.8		
Replace Park Brake Handle			0.5	0.7		
Remove & Reinstall Wheel Lock Nuts			0.1	0.1		
Replace Tapered Brake Pads			(The labor hours to perform this repair are included in V6620. Use T1749 only to claim the applicable parts allowance.)			
Replace Actuator Levers			(The labor hours to perform this repair are included in V6620. Use T1749 only to claim the applicable parts allowance.)			
Reimburse Owner For Previous Repair	95	T1750				

* In addition dealerships will receive 0.1 hours credit for dealer administrative services associated with this campaign. The 0.1 hours allowance is to be entered in the "Other Labor Hours" field with each campaign repair listed for credit. This entry will not require

authorization.

** The \$#.## identified in the "Net Amount" column represents the cost plus 30% for one (1) pint of brake fluid used in conjunction with labor operations.

*** Labor Hours required to replace tapered pads, install actuator levers, and adjust part brake cables are included in the standard campaign labor hours (V6620). No additional time is needed as procedures to perform these repairs are part of the campaign actuator installation procedure.

**** The Labor Hours required for supplemental repairs to complete this campaign are as listed under ADD TIMES. If multiple repairs were required, add appropriate times together. Failed Part Number information can be selected from the "Parts Information" Section of this bulletin.

FAILURE CODE 96 MUST BE USED WITH THE LABOR OPERATION.

Parts required are to be listed in your warranty claim in the normal manner. Parts will be credited at dealer net plus 30% dealer handling allowance.

Dealers will be credited via Warranty Document or Terminal Transmission, whichever is their normal method of submission for payment. Claim must contain all information required and should list the labor operation as outlined.

RECORDING COMPLETION

Repairs submitted for vehicles not involved in the campaign will not be paid.

Campaign completion will be recorded from "PROPERLY COMPLETED AND PAID WARRANTY CLAIMS." Owners are being asked to present the owner reply card for identification to their dealer at the time they bring in their vehicle to have the campaign performed.

Dear Pontiac Owner:

This notice is sent to you in accordance with the requirements of the National Traffic and Motor Vehicle Safety Act.

REASON FOR THIS RECALL

As we informed you in our previous letter, General Motors has determined that a defect which relates to motor vehicle safety exists in 1982-86 Pontiac Firebird and 1984-86 Fiero model vehicles equipped with rear disc brakes and manual transmissions. As we explained in that letter, the parking brake system of these vehicles may contain a nonfunctional parking brake adjuster in the rear disc brake assemblies. This condition may result in a gradual loss of parking brake effectiveness as the rear disc brake pads wear during normal brake usage. As a result, the parking brake system may not be able to hold the vehicle on a steep incline. If the vehicle is parked or left unattended with the transmission in neutral or a gear other than "reverse," the vehicle may roll away and result in personal injury or property damage.

In our previous letter, we informed you that a new parking brake adjuster was in the process of being developed. Development of that new parking brake adjuster is now complete, and parts to repair the affected vehicles are now available.

WHAT WE WILL DO

To improve parking brake performance in your Firebird or Fiero, your Pontiac dealer will install the new design parking brake adjusters in your vehicle. This service will be performed for you at no charge.

WHAT YOU SHOULD DO

Please contact your Pontiac dealer as soon as possible to arrange a service date and so the dealer may order the necessary parts for the repair. Instructions for making this correction have been sent to your Pontiac

Dealer and parts are available. The labor time to perform this service correction is approximately two (2) hours. Please ask your dealer if you wish to know how much additional time will be needed to schedule and process your vehicle.

Be certain to continue to follow the cautions mentioned in our last letter until your vehicle is repaired. Specifically, the manual transmission must be placed in "reverse" gear each time your vehicle is parked and the vehicle's front wheels must be turned into the curb according to your parking conditions.

Also, when exiting your vehicle, check to see that the vehicle remains stationary after removing your foot from the regular brake pedal. If the vehicle moves when the regular brakes are released, do not leave the vehicle in this position. The vehicles must be moved to a less steep grade in order to park safely.

Your Pontiac dealer is best equipped to obtain parts and provide service to ensure your vehicle is corrected as promptly as possible. However, if you take your vehicle to your dealer on the agreed service date, and he does not remedy this condition on that date, or within five (5) days, we recommend you contact the Pontiac Customer Assistance Center by calling: 1-800-762-2737.

After contacting your dealer and the Pontiac Customer Assistance Center, if you are still not satisfied that we have done our best to remedy this condition, without charge and within a reasonable time, you may wish to write the Administrator, National Highway Traffic Safety Administration, 400 Seventh Street, S. W., Washington, DC 20590 or call 1-800-424-9393 (Washington, DC residents use 366-0123).

The enclosed Campaign Owner Reply Card identifies your vehicle. Presentation of this card to your dealer will assist in making the correction in the shortest possible time. If you have sold or traded your vehicle, please let us know by completing the postage-paid Owner Reply Card and returning it to us.

We are sorry to cause you this inconvenience; however, we have taken this action in the interest of your safety and continued satisfaction with our products.